

DEEP WELL

SUBMERSIBLE MOTORS
50Hz & 60Hz



**SUBMERSIBLE
MOTORS - 50Hz**

AYKO positions itself as not just a pump distribution company but as a dependable, technologically sound and one stop solution provider to meet the diverse needs of customers across the globe. Understanding the need of efficient and cost effective pumping solutions and fluid management systems.

AYKO is established by family having more than 37 years of experience

With the vast experience gained in both domestic and international markets arwa products are designed and produced with synergy of best in class technologies and processes with international standards. Most of its products are ISI certified and manufacturing facilities are accredited with ISO 9001.

We are determined to offer reliable & Innovative products and services with high standards, Dedicated to understand & meet customers' requirements on time. We are committed to focus on introducing industry best technologies & Concepts to save energy, protect environment and to give high priority for customers' satisfaction all time.

MODEL NOMENCLATURE

X X XM-(S)(X)XX XXX	
<p>Nominal Dia in Inches 4=4", 6=6", 10=10"</p> <p>Type of motor A- Water Filled</p> <p>Materials of Construction K= CI Top with SS Shell L= Casted SS410 Construction C= Cast Iron Top & Bottom S= Casted SS304 T= Casted SS316</p> <p>Applicable only for 60Hz</p>	<p>Appl. only for spl. requirement M= Mech Seal Type P= PT Sensor H= High temp.(PE2- PA Winding)</p> <hr/> <p>Voltage 110V- A, 120V- C, 220V- D, 230V- E, 330V- I, 440V- L, 460V- M, 525V- N</p> <hr/> <p>Method of Starting W: 1Ph- 2W- PSC M: 1Ph- 3W- CSR S: 1Ph- 3W- CSCR T: 3Ph- D.O.L D: 3Ph- S.D.</p> <hr/> <p>Rated Power in kW (50Hz) 03- 0.37kW, 15-15kW, 220- 22kW, 320- 220kW, A10- 110kW</p> <p>Rated Power in HP (60Hz) 05- 0.5HP, 20- 2HP, 300- 30HP, A50- 150HP, B50- 250HP</p>

4" Water Filled Rewindable Motors

Technical Specifications		50 Hz	60 Hz
Nominal Dia		4" Motor (100mm)	4" Motor (100mm)
Max. Outer Dia		95mm	3.74 Inches
Power Range	1Ph	0.37 to 2.2 kW	0.5 to 3 HP
	3Ph	0.37 to 7.5 kW	0.5 to 10 HP
Version	1Ph	220 / 230 V - 50Hz	220/230V, 60Hz, A.C Supply
	3Ph	380 - 415 V - 50Hz	220/230/380/460V, 60Hz, A.C Supply
Nominal Speed		2900 rpm	3450 rpm
Class of Insulation		Y / F	Y / F
Degree of protection		IP 58	IP 58
Direction of rotation		Counter-clock wise	Counter-clock wise
Type of duty		S1 (Continues)	S1 (Continues)
Minimum cooling flow		0.15 m/sec	0.5 ft/sec
Max. Liquid temp.		33° C	33° C (91.4°F)
starts per hour		20 Times	20 Times
Method of starting	1Ph	Capacitor Start Capacitor Run (CSCR)	Capacitor Start Capacitor Run
	3Ph	Direct On Line (DOL)	(CSCR) Direct On Line (DOL)
Cable lead-out		Permanently Connected	Permanently Connected
		3 / 4 Core PVC Flat Cable	3 / 4 Core PVC Flat Cable

Materials of Construction	4ACM	4ALM	4ASM
Upper & Lower Housing	CI, FG 200	Casted SS 410	Casted SS 304
Stator Shell	SS 202	SS 410	SS 304
Thrust Pad	CARBON / TEFLON	CARBON / TEFLON	CARBON / TEFLON
Thrust Bearing	CI, FG 200/ SS 420	SS 410 / SS 420	SS 304 / SS 420
Diaphragm	NITRILE RUBBER	NITRILE RUBBER	NITRILE RUBBER
Motor Base	CI, FG 200	SS 410	SS 304
Upper housing shell	CI, FG 200	SS 410	SS 304
Shaft	SS 420 / 431	SS 420 / 431	SS 420 / 431
Sleeve	SS 410	SS 410	SS 410

Features

- Easy to dismantle & repair
- High Operating Efficiency
- Specially designed 3 layered Insulation (Polyster+2BOPP) winding wire for better thermal protection
- Spl. Magnet provision at motor base to prevent from free metal particles
- Mounting dimensions as per NEMA standard
- Kingsburry type Thrust bearing to withstand high axial loads
- Spring action pressure compensating Diaphragm
- Specially designed forged MS stator end rings
- Low Voltage motors can be supplied, on request



In view of continuous improvements in our design and process, the information, dimensions and specifications given herein are subject to change without notice.

4" Motor Cross Sectional View

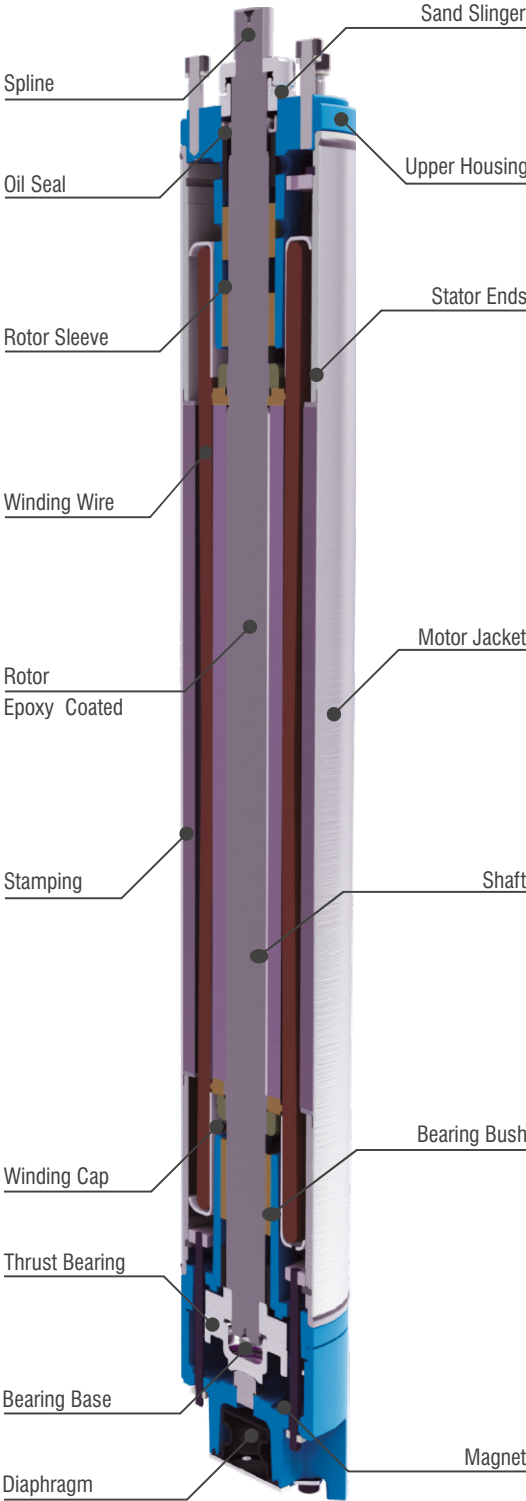

In view of continuous improvements in our design and process, the information, dimensions and specifications given herein are subject to change without notice.

Technical Details

50Hz, Single Phase, 230V Water Filled Motor (GSCR)

Model	kW	HP	Full load Current (A)	Starting Current (A)	Eff. (%)	P.F. cosØ	Max. Down thrust Load (N)	Starting Torque (Nm)	Torque (Nm)
4ASM-03S	0.37	0.5	5.3	10.13	40	0.64	3000	2	1.2
4ASM-05S	0.55	0.75	5.5	11.5	42	0.65	3000	2.9	1.8
4ASM-07S	0.75	1	7.5	14.17	46	0.65	3000	4.1	2.5
4ASM-11S	1.1	1.5	10.5	20.15	49	0.65	3000	6.1	3.7
4ASM-15S	1.5	2	13.8	24.2	52	0.66	3000	8.3	4.9
4ASM-22S	2.2	3	19.8	34.6	60	0.66	6500	13.3	7.4

50Hz, Three Phase, 380 - 415V Water Filled Motor (D.O.L.)

Model	kW	HP	Full load Current (A)	Starting Current (A)	Eff. (%)	P.F. cosØ	Max. Down thrust Load (N)	Starting Torque (Nm)	Torque (Nm)
4ASM-03T	0.37	0.5	3.25	5.2	60	0.75	3000	2.2	1.2
4ASM-05T	0.55	0.75	2.75	9.64	50	0.6	3000	3.4	1.9
4ASM-07T	0.75	1	3	10.27	56	0.6	3000	4.5	2.5
4ASM-11T	1.1	1.5	4	13.83	56	0.61	3000	6.7	3.7
4ASM-15T	1.5	2	4.8	16.44	60	0.61	3000	9	5
4ASM-22T	2.2	3	6.9	25.06	63	0.61	6500	14.1	7.5
4ASM-30T	3	4	9	31.3	63	0.62	6500	19	10
4ASM-37T	3.7	5	10.6	36.97	64	0.62	6500	22	12.4
4ASM-40T	4	5.5	11	51	71	0.82	6500	23	13.1
4ASM-55T	5.5	7.5	14.5	49.8	68	0.65	6500	33.7	18.7
4ASM-75T	7.5	10	19.8	119	72	0.82	6500	45.5	25

Dimensional Details

Model	kW	HP	Cable Size (sq.mm)	Cable Length (m)	Height (mm)	Net Weight (kg)
4ASM-03S	0.37	0.5	1.5	1.5	472.5	17
4ASM-05S	0.55	0.75	1.5	1.5	494.5	17.4
4ASM-07S	0.75	1	1.5	1.5	514.5	19
4ASM-11S	1.1	1.5	2.5	1.5	549.5	20
4ASM-15S	1.5	2	2.5	1.5	594.5	22
4ASM-22S	2.2	3	2.5	2.0	664.5	25.4
4ASM-03T	0.37	0.5	1.5	1.5	472.5	15.5
4ASM-05T	0.55	0.75	1.5	1.5	493	18
4ASM-07T	0.75	1	1.5	1.5	514.5	19.5
4ASM-11T	1.1	1.5	1.5	1.5	549.5	20.5
4ASM-15T	1.5	2	1.5	1.5	594.5	22.5
4ASM-22T	2.2	3	1.5	2.0	664.5	26
4ASM-30T	3	4	1.5	2.0	724.5	28
4ASM-37T	3.7	5	2.5	2.0	764.5	31
4ASM-40T	4	5.5	2.5	2.0	762.5	31
4ASM-55T	5.5	7.5	4.0	3.0	852.5	36
4ASM-75T	7.5	10	4.0	3.0	1120.0	43



Replace the 3rd digit in model name with 'L' for SS410 construction and 'S' with SS304 Construction.

In view of continuous improvements in our design and process, the information, dimensions and specifications given herein are subject to change without notice.

Technical Details

60Hz, Single Phase, 220 / 230V 3Wire Motor (CSCR)

Model	HP	kW	Full load Current (A)	Eff. (%)	P.F. cos ϕ	Max. Down thrust Load (N)	Cable Size (sq.mm)	Cable Length (m)	Height (mm)	Net Weight (kg)
4ASM-S05S	0.5	0.37	9.3	58	0.57	3000	1.5	1.5	472.5	16.6
4ASM-S07S	0.75	0.55	12.4	63	0.59	3000	1.5	1.5	492.5	17.4
4ASM-S10S	1	0.75	14.9	65	0.68	3000	1.5	1.5	512.5	19
4ASM-S15S	1.5	1.1	18.7	68	0.71	3000	2.5	1.5	547.5	20
4ASM-S20S	2	1.5	20.9	71	0.83	3000	2.5	2.0	639.5	22
4ASM-S30S	3	2.2	27.6	70	0.90	6500	2.5	2.0	662.5	25.4

60Hz, Three Phase, 220/230V Motor (D.O.L.)

Model	HP	kW	Full load Current (A)	Eff. (%)	P.F. cos ϕ	Max. Down thrust Load (N)	Cable Size (sq.mm)	Cable Length (m)	Height (mm)	Net Weight (kg)
4ASM-S05TD	0.5	0.37	2.3	65	0.75	3000	1.5	1.5	472.5	17
4ASM-S07TD	0.75	0.55	3.1	67	0.77	3000	1.5	1.5	492.5	18
4ASM-S10TD	1	0.75	4.0	70	0.77	3000	1.5	1.5	512.5	19.5
4ASM-S15TD	1.5	1.1	5.2	74	0.79	3000	2.5	1.5	547.5	20.5
4ASM-S20TD	2	1.5	7.5	72	0.79	3000	2.5	1.5	639.5	22.5
4ASM-S30TD	3	2.2	10.1	73	0.78	6500	2.5	2.0	662.5	26
4ASM-S40TD	4	3	12.3	74	0.80	6500	2.5	2.0	722.5	28
4ASM-S50TD	5	3.7	16.3	76	0.80	6500	2.5	2.0	762.5	31
4ASM-S55TD	5.5	4	18.8	76	0.74	6500	4.0	3.0	762.5	31
4ASM-S75TD	7.5	5.5	24.5	76	0.75	6500	4.0	3.0	852.5	36

60Hz, Three Phase, 380V Motor (D.O.L.)

Model	HP	kW	Full load Current (A)	Eff. (%)	P.F. cos ϕ	Max. Down thrust Load (N)	Cable Size (sq.mm)	Cable Length (m)	Height (mm)	Net Weight (kg)
4ASM-S05T	0.5	0.37	1.3	65	0.75	3000	1.5	1.5	472.5	17
4ASM-S07T	0.75	0.55	1.8	67	0.77	3000	1.5	1.5	492.5	18
4ASM-S10T	1	0.75	2.3	70	0.77	3000	1.5	1.5	512.5	19.5
4ASM-S15T	1.5	1.1	3	74	0.79	3000	2.5	1.5	547.5	20.5
4ASM-S20T	2	1.5	4.3	72	0.79	3000	2.5	1.5	639.5	22.5
4ASM-S30T	3	2.2	5.8	73	0.78	6500	2.5	2.0	662.5	26
4ASM-S40T	4	3	7.1	74	0.8	6500	2.5	2.0	722.5	28
4ASM-S50T	5	3.7	9.4	76	0.8	6500	2.5	2.0	762.5	31
4ASM-S55T	5.5	4	10.8	76	0.74	6500	4.0	3.0	762.5	31
4ASM-S75T	7.5	5.5	14.1	76	0.75	6500	4.0	3.0	852.5	36

60Hz, Three Phase, 440/460V Motor (D.O.L.)

Model	HP	kW	Full load Current (A)	Eff. (%)	P.F. cos ϕ	Max. Down thrust Load (N)	Cable Size (sq.mm)	Cable Length (m)	Height (mm)	Net Weight (kg)
4ASM-S05TM	0.5	0.37	1.1	65	0.75	3000	1.5	1.5	472.5	17
4ASM-S07TM	0.75	0.55	1.6	67	0.77	3000	1.5	1.5	492.5	18
4ASM-S10TM	1	0.75	2.0	70	0.77	3000	1.5	1.5	512.5	19.5
4ASM-S15TM	1.5	1.1	2.6	74	0.79	3000	1.5	1.5	547.5	20.5
4ASM-S20TM	2	1.5	3.7	72	0.79	3000	1.5	1.5	639.5	22.5
4ASM-S30TM	3	2.2	5.0	73	0.78	6500	1.5	2.0	662.5	26
4ASM-S40TM	4	3	6.2	74	0.80	6500	2.5	2.0	722.5	28
4ASM-S50TM	5	3.7	8.2	76	0.80	6500	2.5	2.0	762.5	31
4ASM-S55TM	5.5	4	9.4	76	0.74	6500	2.5	3.0	762.5	31
4ASM-S75TM	7.5	5.5	12.3	76	0.75	6500	2.5	3.0	852.5	36

In view of continuous improvements in our design and process, the information, dimensions and specifications given herein are subject to change without notice.

6" Water Filled Rewindable Motors

Technical Specifications		50 Hz	60 Hz
Nominal Dia		6" Motor (150mm)	6" Motor
Max. Outer Dia		144mm	5.67 Inches
Power Range		4 to 45 kW	5.5 to 50 HP
Version	3Ph	380-415V, 50Hz, A.C. Supply	220/230/380/440/460V, 60 Hz, A.C. Supply
Nominal Speed		2900 rpm	3450 rpm
Class of Insulation		Y / F	Y / F
Degree of protection		IP58 / IP68	IP 58 / IP 68
Direction of rotation		Counter-clock Wise	Counter-clock Wise
Type of duty		S1 (Continues)	S1 (Continues)
Minimum cooling flow		0.15 m/sec	0.5 ft/sec
Max. Liquid temp.		33° C / 70° C (PE2-PA Winding)	33° C (91.4°F) / 70° C (PE2-PA Winding)
starts per hour		20 Times	20 Times
Method of starting		4.0kW to 45kW Direct On Line (D.O.L.)	4.0 kW to 5.5 kW Direct On Line (D.O.L.)
		5.5kW to 45kW Star Delta (S.D.)	5.5 kW to 30.0 kW Star Delta (DOL / S.D.)
Cable leadout type		Permanently Connected 3 / 4 Core PVC Flat Cable	Permanently Connected 3 / 4 Core PVC Flat Cable

Materials of Construction	6ACM	6ALM	6ASM	6ATM
Upper & Lower Housing	CI,FG 200 / 260	Casted SS 410	Casted SS 304	Casted SS 316
Stator Shell	SS 202	SS 410	SS 304	SS 316
Thrust Pad	CARBON / TEFLON	CARBON / TEFLON	CARBON / TEFLON	CARBON / TEFLON
Thrust Bearing	CI, FG 200/ SS 420	SS 410 / SS 420	SS 304 / SS 420	SS 316 / SS 420
Diaphragm	NITRILE RUBBER	NITRILE RUBBER	NITRILE RUBBER	NITRILE RUBBER
Motor Base	CI, FG 200/260	SS 410	SS 304	SS 316
Upper Housing Shell	CI, FG 200/260	CI, FG 200/260	CI, FG 200/260	CI, FG 200/260
Shaft	SS 420/431	SS 420/431	SS 420/431	SS 420/431
Sleeve	SS 410	SS 410	SS 410	SS 410

Features

- Easy to dismantle & repair
- High Operating Efficiency
- Specially designed 3 layered Insulation (Polyster+2BOPP) winding wire for better thermal protection
- Spl. Magnet provision at motor base to prevent from free metal particles
- Mounting dimensions as per NEMA standard
- Kingsburry type Thrust bearing to withstand high axial loads
- Spring action pressure compensating Diaphragm
- Specially designed forged MS stator end rings
- On request, Motors can be supplied with PE2-PA winding wire for high temp. applications.
- Motors with Mechanical Seal & PT sensors available, on request



In view of continuous improvements in our design and process, the information, dimensions and specifications given herein are subject to change without notice.

6" Motor Cross Sectional View

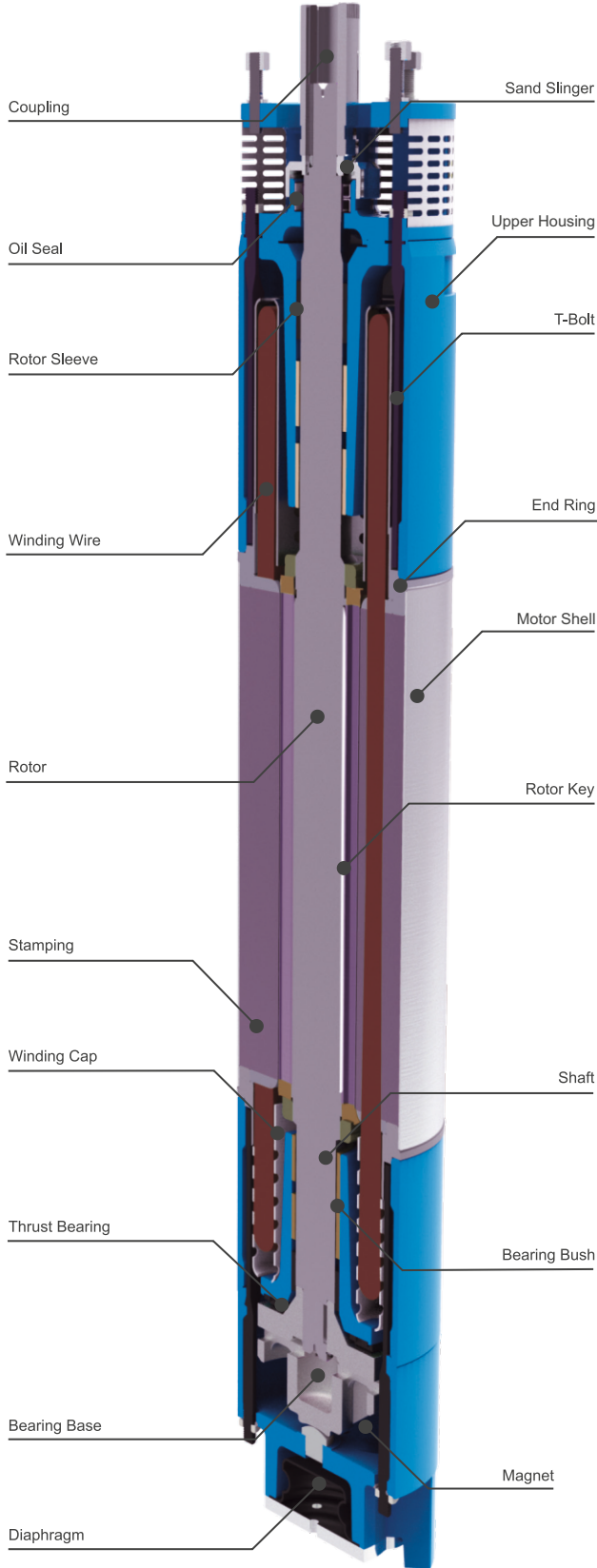

In view of continuous improvements in our design and process, the information, dimensions and specifications given herein are subject to change without notice.

Technical Details

50Hz, Three Phase 380-415V, Water Filled Motor (D.O.L.& S.D.)

Model	kW	HP	Full load Current (A)	Starting Current (A)	Eff. (%)	P.F. cos ϕ	Max. Down thrust Load (N)	Starting Torque (Nm)	Torque (Nm)
6ACM-40T	4	5.5	10	44.69	68	0.7	15500	20	14
6ACM-45T	4.5	6	12	50.97	70	0.71	15500	21	15
6ACM-55T	5.5	7.5	14.5	57.16	73	0.71	15500	24	18
6ACM-75T	7.5	10	19.5	79.51	74	0.71	15500	27	25
6ACM-93T	9.3	12.5	25	94.59	75	0.72	15500	35	31
6ACM-110T	11	15	29	113.12	76	0.72	15500	43	37
6ACM-130T	13	17.5	34	122.4	77	0.72	15500	51	43
6ACM-150T	15	20	39	133.1	78	0.73	15500	62	49
6ACM-185T	18.5	25	45	162.8	80	0.73	15500	98	61
6ACM-220T	22	30	53	189.71	80	0.75	15500	118	74
6ACM-260T	26	35	66	215.2	81	0.76	27500	146	84
6ACM-300T	30	40	72	241.5	83	0.76	27500	196	98
6ACM-370T	37	50	85	420	82	0.82	27500	242	122
6ACM-450T	45	60	96	464	82	0.82	27500	393	150

Dimensional Details

Model	kW	HP	Cable Size D.O.L. (sq. mm)	Cable Size S.D. (sq. mm)	Cable Length (m)	Height (mm)	Net Weight (kg)
6ACM-40T	4	5.5	4	-	3.0	704	49
6ACM-45T	4.5	6	4	-	3.0	704	51
6ACM-55T	5.5	7.5	4	2.5	3.0	774	59.0
6ACM-75T	7.5	10	4	2.5	3.0	819	65.0
6ACM-93T	9.3	12.5	6	2.5	3.0	849	69.0
6ACM-110T	11	15	6	4	3.0	909	76.0
6ACM-130T	13	17.5	10	4	3.0	939	79.0
6ACM-150T	15	20	10	4	3.0	989	85.0
6ACM-185T	18.5	25	10	4	4.0	1039	92.0
6ACM-220T	22	30	10	4	4.0	1129	100.0
6ACM-260T	26	35	10	6	4.0	1164	105
6ACM-300T	30	40	16	6	4.0	1339	118
6ACM-370T	37	50	16	6	5.0	1312	128
6ACM-450T	45	60	16	10	5.0	1387	120



In view of continuous improvements in our design and process, the information, dimensions and specifications given herein are subject to change without notice.

Technical Details

60Hz, Three Phase, 220/230V Water filled motor

Model	HP	kW	Full load Current (A)	Eff. (%)	P.F. cos ϕ	Max. Down thrust Load (N)	Cable Size (sq.mm)	Cable Length (m)	Height (mm)	Net Weight (kg)
6ACM-S55TE	5.5	4	17.3	73	0.8	15500	2.5	3.0	646	51
6ACM-S60TE	6	4.5	20.0	75	0.82	15500	2.5	3.0	661	53
6ACM-S75TE	7.5	5.5	24.5	76	0.85	15500	4.0	3.0	716	59
6ACM-S100TE	10	7.5	31.1	78	0.87	15500	6.0	3.0	761	65
6ACM-S125TE	12.5	9.3	36.7	79	0.87	15500	6.0	3.0	791	69
6ACM-S150TE	15	11	44.7	81	0.86	15500	10.0	3.0	851	76
6ACM-S175TE	17.5	13	52.7	80	0.86	15500	10.0	3.0	881	79
6ACM-S200TE	20	15	60.0	80	0.86	15500	10.0	3.0	931	85
6ACM-S250TE	25	18.5	68.2	86	0.88	15500	16.0	4.0	981	92
6ACM-S300TE	30	22	86.4	86	0.84	15500	16.0	4.0	1071	100

60Hz, Three Phase, 380V Water filled motor

Model	HP	kW	Full load Current (A)	Eff. (%)	P.F. cos ϕ	Max. Down thrust Load (N)	Cable Size (sq.mm)	Cable Length (m)	Height (mm)	Net Weight (kg)
6ACM-S55T	5.5	4	9.5	73	0.8	15500	2.5	3.0	646	51
6ACM-S60T	6	4.5	11	75	0.82	15500	2.5	3.0	661	53
6ACM-S75T	7.5	5.5	13.5	76	0.85	15500	4.0	3.0	716	59
6ACM-S100T	10	7.5	17.1	78	0.87	15500	6.0	3.0	761	65
6ACM-S125T	12.5	9.3	20.2	79	0.87	15500	6.0	3.0	791	69
6ACM-S150T	15	11	24.6	81	0.86	15500	10.0	3.0	851	76
6ACM-S175T	17.5	13	29	80	0.86	15500	10.0	3.0	881	79
6ACM-S200T	20	15	33	80	0.86	15500	10.0	3.0	931	85
6ACM-S250T	25	18.5	37.5	86	0.88	15500	10.0	4.0	981	92
6ACM-S300T	30	22	47.5	86	0.84	15500	16.0	4.0	1071	100
6ACM-S350T	35	26	55.3	84	0.84	27500	16.0	4.0	1152	110
6ACM-S400T	40	30	65	84	0.84	27500	16.0	4.0	1236	128
6ACM-S500T	50	37	83	83	0.82	27500	16.0	4.0	1359	138

60Hz, Three Phase, 440/460V Water filled motor

Model	HP	kW	Full load Current (A)	Eff. (%)	P.F. cos ϕ	Max. Down thrust Load (N)	Cable Size (sq.mm)	Cable Length (m)	Height (mm)	Net Weight (kg)
6ACM-S55TM	5.5	4	8.6	73	0.8	15500	2.5	3.0	646	51
6ACM-S60TM	6	4.5	10.0	75	0.82	15500	2.5	3.0	661	53
6ACM-S75TM	7.5	5.5	12.3	76	0.85	15500	4.0	3.0	716	59
6ACM-S100TM	10	7.5	15.5	78	0.87	15500	6.0	3.0	761	65
6ACM-S125TM	12.5	9.3	18.4	79	0.87	15500	6.0	3.0	791	69
6ACM-S150TM	15	11	22.4	81	0.86	15500	10.0	3.0	851	76
6ACM-S175TM	17.5	13	26.4	80	0.86	15500	10.0	3.0	881	79
6ACM-S200TM	20	15	30.0	80	0.86	15500	10.0	3.0	931	85
6ACM-S250TM	25	18.5	34.1	86	0.88	15500	10.0	4.0	981	92
6ACM-S300TM	30	22	43.2	86	0.84	15500	10.0	4.0	1071	100
6ACM-S350TM	35	26	50.3	84	0.84	27500	16.0	4.0	1152	110
6ACM-S400TM	40	30	59.1	84	0.84	27500	16.0	4.0	1236	128
6ACM-S500TM	50	37	74	83	0.82	27500	16.0	4.0	1359	138

In view of continuous improvements in our design and process, the information, dimensions and specifications given herein are subject to change without notice.

8" Water Filled Rewindable Motors

Technical Specifications		50 Hz	60 Hz
Nominal Dia		8" Motor (200mm)	8" Motor
Max. Outer Dia		190mm	7.5 Inches
Power Range		37 to 93 kW	50 to 125 HP
Version	3Ph	380-415 V 50 Hz, A.C. Supply	380V / 440V / 460V 60 Hz, A.C. Supply
Nominal Speed		2900 rpm	3450 rpm
Class of Insulation		Y / F	Y / F
Degree of protection		IP 68	IP 68
Direction of rotation		Counter-Clock Wise	Counter-Clock Wise
Type of duty		S1 (Continues)	S1 (Continues)
Minimum cooling flow		0.5 m/sec	0.5 m/sec
Max. Liquid temp.		33° C	33° C
starts per hour		10 Times	10 Times
Method of starting		37 kW - 93 kW (DOL & S.D.)	37.0 kW - 63.0 kW (DOL & S.D.)
Cable leadout type		3 / 4 Core PVC Flat Cable	3 / 4 Core PVC Flat Cable

Materials of Construction	8ACM	8ASM	8ATM
Upper & Lower Housing	CI,FG 200/260	Casted SS304	Casted SS316
Stator Shell	SS 202	SS304	SS316
Thrust Pad	CARBON / TEFLON	CARBON / TEFLON	CARBON / TEFLON
Thrust Bearing	CI, FG 200/ SS 420	Ss304 / Ss420	Ss316 / Ss420
Diaphragm	NITRILE RUBBER	NITRILE RUBBER	NITRILE RUBBER
Motor Base	CI, FG 200/260	SS304	SS316
upper housing shell	CI, FG 200/260	SS304	SS316
Shaft	SS 420/431	SS 420/431	SS 420/431
Sleeve	SS 410	SS 410	SS 410

Features

- Easy to dismantle & repair
- High Operating Efficiency
- Specially designed 3 layered Insulation (Polyster+2BOPP) winding wire for better thermal protection
- Spl. Magnet provision at motor base to prevent from free metal particles
- Mounting dimensions as per NEMA standard
- Kingsburry type Thrust bearing to withstand high axial loads
- Spring action pressure compensating Diaphragm
- Specially designed forged MS stator end rings
- On request, Motors can be supplied with PE2-PA winding wire for high temp. applications.
- Motors with Mechanical Seal & PT sensors available, on request

8" Motor Cross Sectional View

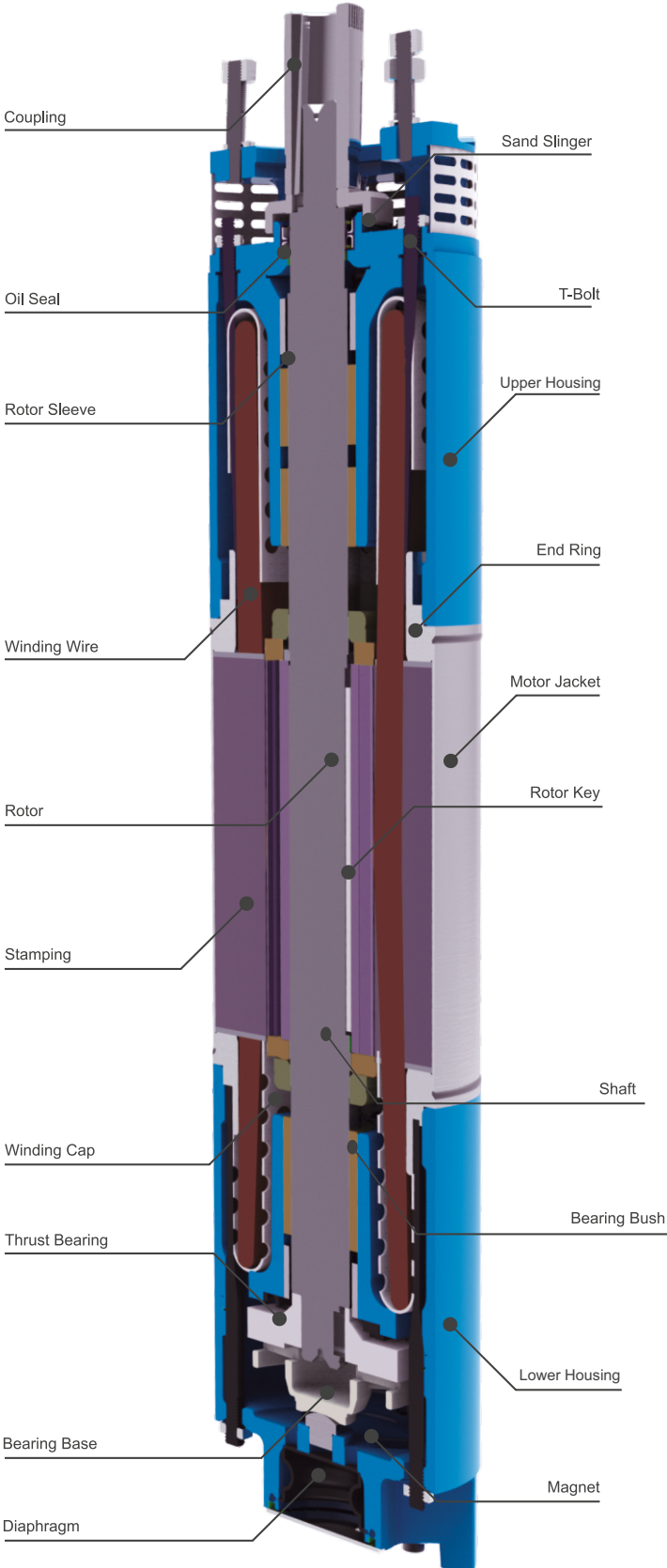

In view of continuous improvements in our design and process, the information, dimensions and specifications given herein are subject to change without notice.

Technical Details

50Hz, Three Phase, 380-415V Water Filled Motor

Model	kW	HP	Full load Current (A)	Starting Current (A)	Eff. (%)	P.F. cos ϕ	Max. Down thrust Load (N)	Starting Torque (Nm)	Torque (Nm)
8ACM-370T 122	37	50	85	400	82	0.84	45500	200	
8ACM-450T	45	60	100	520	82	0.84	45500	268	149
8ACM-550T 180	55	75	120	660	83	0.84	45500	370	
8ACM-630T	63	85	135	720	83	0.84	45500	410	

Dimensional Details

Model	kW	HP	Cable Size D.O.L. (sq. mm)	Cable Size S.D. (sq. mm)	Cable Length (m)	Height (mm)	Net Weight (kg)
8ACM-370T	37	50	16.0	10	4.0	1236.5	166.0
8ACM-450T	45	60	16.0	10	4.0	1351.5	188.0
8ACM-550T	55	75	35.0	25	5.0	1431.5	203.0
8ACM-630T	63	85	35.0	25	5.0	1491.5	213.0
8ACM-750T	75	100	35.0	35	5.0	1561	230
8ACM-930T	93	125	35.0	35	5.0	1634	245

60Hz, Three Phase, 380V Water Filled Motor

Model	HP	kW	Full load Current (A)	Starting Current (A)	Eff. (%)	P.F. cos ϕ	Max. Down thrust Load (N)	Cable Size (sq. mm)	Cable Length (m)	Height (mm)	Net Weight (kg)
8ACM-S500T	50	37	78	377	84	0.88	45500	25	4.0	1236	166
8ACM-S600T	60	45	92.5	470	85	0.88	45500	25	4.0	1351	188
8ACM-S750T	75	55	113.8	560	85	0.88	45500	35	5.0	1431	203
8ACM-S850T	85	63	135.5	690	86	0.89	45500	35	5.0	1491	213
8ACM-SA00T	100	75	150	765	85	0.9	45500	35	5.0	1491	215
8ACM-SA10T	110	81	164	833	84	0.89	55000	35	5.0	1570	220
8ACM-SA25T	125	93	187	942	84	0.89	55000	35	5.0	1630	225

60Hz, Three Phase, 440/460V Water Filled Motor

Model	HP	kW	Full load Current (A)	Starting Current (A)	Eff. (%)	P.F. cos ϕ	Max. Down thrust Load (N)	Cable Size (sq. mm)	Cable Length (m)	Height (mm)	Net Weight (kg)
8ACM-S500TM	50	37	71	308	84	0.88	45500	25	4.0	1236	166
8ACM-S600TM	60	45	84	382	85	0.88	45500	25	4.0	1351	188
8ACM-S750TM	75	55	103	458	85	0.88	45500	35	5.0	1431	203
8ACM-S850TM	85	63	120	563	86	0.89	45500	35	5.0	1491	213
8ACM-SA00TM	100	75	127	625	85	0.9	45500	35	5.0	1491	215
8ACM-SA10TM	110	81	134	681	84	0.89	55000	35	5.0	1570	220
8ACM-SA25TM	125	93	153	770	84	0.89	55000	25	5.0	1630	225

In view of continuous improvements in our design and process, the information, dimensions and specifications given herein are subject to change without notice.

SUBMERSIBLE MOTORS

Technical Specifications	50 Hz	60 Hz
Nominal Dia	10" Motor (250mm)	10" Motor (250mm)
Max. Outer Dia	231mm	9.1 Inches
Power Range	81 to 185 kW	110 to 250 HP
Version	3Ph - 380-415 V 50 Hz, A.C. Supply	3Ph - 380V/460V 60 Hz, A.C. Supply
Nominal Speed	2900 rpm	3450 rpm
Class of Insulation	Y	Y
Degree of protection	IP 68	IP 68
Direction of rotation	Counter-clock Wise	Counter-clock Wise
Type of duty	S1 (Continues)	S1 (Continues)
Minimum cooling flow	0.5 m/sec	0.5 m/Sec
Max. Liquid temp.	33° C	33° C (91.4 °F)
starts per hour	10 Times	10 Times
Method of starting	81 kW - 185 kW (DOL & S.D.)	110 HP - 250HP (DOL & S.D.)
Cable leadout type	3 / 4 Core PVC Flat Cable	3 / 4 Core PVC Flat Cable

Materials of Construction	10ACM	10ASM	10ATM
Upper & Lower Housing	CI,FG 200/260	Casted SS304	Casted SS316
Stator Shell	SS 202	SS304	SS316
Thrust Pad	CARBON / TEFLON	CARBON / TEFLON	CARBON / TEFLON
Thrust Bearing	CI, FG 200/ SS 420	SS304 / SS420	SS316 / SS420
Diaphragm	NITRILE RUBBER	NITRILE RUBBER	NITRILE RUBBER
Motor Base	CI, FG 200/260	SS304	SS316
upper housing shell	CI, FG 200/260	SS304	SS316
Shaft	SS 420/431	SS 420/431	SS 420/431
Sleeve	SS 410	SS 410	SS 410

Features

- Easy to dismantle & repair
- High Operating Efficiency
- Mounting dimensions as per NEMA standard
- Kingsburry type Thrust bearing to withstand high axial loads
- Spring action pressure compensating Diaphragm
- On request, Motors can be supplied with PE2-PA winding wire for high temp. applications.
- Motors with Mechanical Seal & PT sensors available, on request



In view of continuous improvements in our design and process, the information, dimensions and specifications given herein are subject to change without notice.

10" Motor Exploded View

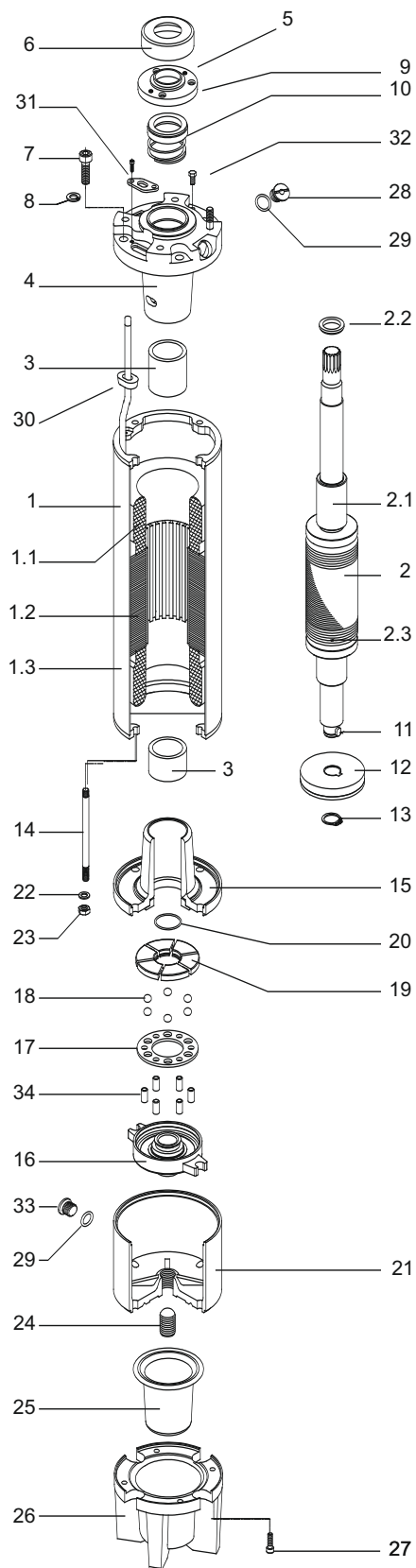

No	Part Name
1	Stator
1.1	Winding wire
1.2	Stator package
1.3	Stator shell
2	Rotor
2.1	Shaft sleeve
2.2	Balance ring
2.3	Copper ring
3	Radial bearing
4	Upper bearing body
5	Bushing
6	Slinger (sand guard)
7	Hexagon socket cap screws
8	Copper ring
9	Cover seal
10	Mechanical seal
11	Axial thrust bearing key
12	Axial thrust bearing
13	Retaining ring
14	Tie rod
15	Lower bearing body
16	Thrust bearing support
17	Ball holder
18	Thrust bearing ball
19	Tilting pads
20	O-ring
21	Thrust bearing body
22	Copper ring
23	Nut
24	Screw (thrust bearing base)
25	Membrane
26	Membrane body
27	Hexagon socket cap screws
28	Check-valve
29	O-ring
30	Cable seal
31	Seal cover
32	Nut
33	Plug (3/8")
34	Ball holder pins

In view of continuous improvements in our design and process, the information, dimensions and specifications given herein are subject to change without notice.

Technical Details

50Hz, Three Phase, 380-415V Water filled motor

Model	kW	HP	Full load Current (A)	Starting Current (A)	Eff. (%)	P.F. % $\cos\theta$	Max. Down thrust Load (N)	Cable Size D.O.L. (sq.mm)	Cable Size S.D. (sq.mm)	Cable Length (m)	Height (mm)	Net Weight (kg)
10ACM-810T 225	81	110	153	590	85	0.89	75000	25	16	5	1370	
10ACM-930T	93	125	174	671	85	0.89	75000	25	16	5	1430	274
10ACM-A10T	110	150	210	811	85	0.88	75000	25(2)	25	5	1510	299
10ACM-A30T 328	130	175	238	919	87	0.89	75000	25(2)	25	5	1610	
10ACM-A50T	150	200	274	1059	87	0.89	75000	35(2)	35	5	1740	368

60Hz, Three Phase, 380V Water filled motor

Model	HP	kW	Full load Current (A)	Starting Current (A)	Eff. (%)	P.F. % $\cos\theta$	Max. Down thrust Load (N)	Cable Size D.O.L. (sq.mm)	Cable Size S.D. (sq.mm)	Cable Length (m)	Height (mm)	Net Weight (kg)
10ACM-SA10T 225	110	81	166	590	86	0.87	75000	25	16	5	1370	
10ACM-SA25T	125	93	181	671	87	0.89	75000	25	16	5	1430	274
10ACM-SA50T	150	110	220	811	87	0.89	75000	25(2)	25	5	1510	299
10ACM-SA75T 328	175	130	225	919	87	0.89	75000	25(2)	25	5	1610	
10ACM-SB00T	200	150	290	1059	88	0.89	75000	35(2)	35	5	1740	368

60Hz, Three Phase, 460V Water filled motor

Model	HP	kW	Full load Current (A)	Starting Current (A)	Eff. (%)	P.F. % $\cos\theta$	Max. Down thrust Load (N)	Cable Size D.O.L. (sq.mm)	Cable Size S.D. (sq.mm)	Cable Length (m)	Height (mm)	Net Weight (kg)
10ACM-SA10T 225	110	81	131	663	84	0.87	75000	25	16	5	1370	
10ACM-SA25T	125	93	149	748	84	0.89	75000	25	16	5	1430	274
10ACM-SA50T	150	110	180	910	84	0.89	75000	25(2)	25	5	1510	299
10ACM-SA75T 328	175	130	207	1050	85	0.89	75000	25(2)	25	5	1610	
10ACM-SB00T	200	150	236	1197	85	0.89	75000	35(2)	35	5	1740	368

Submersible Motor 3P - 400V, 50Hz, Direct on Line (D.O.L)

Rating		Cable Size sq.mm, copper wire - 70°C rated insulation															
KW	HP	2.5	4	6	10	16	25	35	50	70	95	120	150	185	240	300	400
4	5,5	180	290	430	710												
5,5	7,5	130	210	320	530	830											
7,5	10	80	150	230	390	610	940										
9,3	12,5	80	130	190	320	510	770										
11	15	60	100	160	270	430	650	890									
13	17,5		90	140	230	370	560	770									
15	20		80	120	200	320	490	880	920								
18,5	25			100	160	260	400	540	740	980							
22	30				140	220	340	470	630	840							
26	35				120	190	290	380	540	720	920						
30	40					150	250	340	470	520	790	940					
37	50					130	200	280	380	600	640	760	890	1020			
45	60						170	240	330	440	570	890	810	940			
52	70						150*	210	290	390	500	800	710	820	980		
55	75						140*	190	270	360	470	5600	660	770	910		
60	80							180	250	340	440	530	630	730	870	1010	
67	90							160*	220	300	390	460	550	630	750	860	1000
75	100								200*	270	350	420	490	570	680	780	910
83	111								180*	250	320	390	450	530	630	730	850
85	114									230	290	350	410	480	570	650	750
93	125									220*	280	340	390	460	550	620	720
110	150										220	270	310	360	420	480	550
130	175										200*	240	280	330	390	440	520
150	200											200*	240	280	330	380	440
185	250													210*	250	280	330

Submersible Motor 3P - 400V, 50Hz, Star Delta (S.D.)

Rating		Cable Size sq.mm, copper wire - 70°C rated insulation															
KW	HP	2.5	4	6	10	16	25	35	50	70	95	120	150	185	240	300	400
4	5,5	270	430	640													
5,5	7,5	190	310	480	790												
7,5	10	130	220	340	580	910											
9,3	12,5	120	180	280	480	760											
11	15	80	150	240	400	640	970										
13	17,5	70	130	210	340	550	840										
15	20	70	120	180	300	480	730	1020									
18,5	25	60	90	150	240	390	600	810									
22	30		70	120	210	330	510	700	940								
26	35		60*	100	180	280	430	580	810								
30	40			90	150	240	370	610	700	930							
37	50				120	190	300	420	570	750	950						
45	60				100	160	250	360	490	550	850						
52	70				90*	150	220	310	430	580	750	800					
55	75					130	210	280	400	540	700	840	890				
60	80					120	190	270	370	510	660	790	940				
67	90					100	180	240	330	450	580	690	820	940			
75	100						90*	150	210	300	400	520	630	730	850	1020	
83	111																
85	114						130	190	270	370	480	580	670	790	940		
93	125						180*	180	250	340	430	520	610	720	850	870	
110	150						120*	160	240	330	420	510	580	690	820	830	
130	175							130*	190	250	330	400	460	540	630	720	820
150	200								160*	220	300	360	420	490	580	660	780
185	250								.150*	190	250	300	360	420	490	570	660

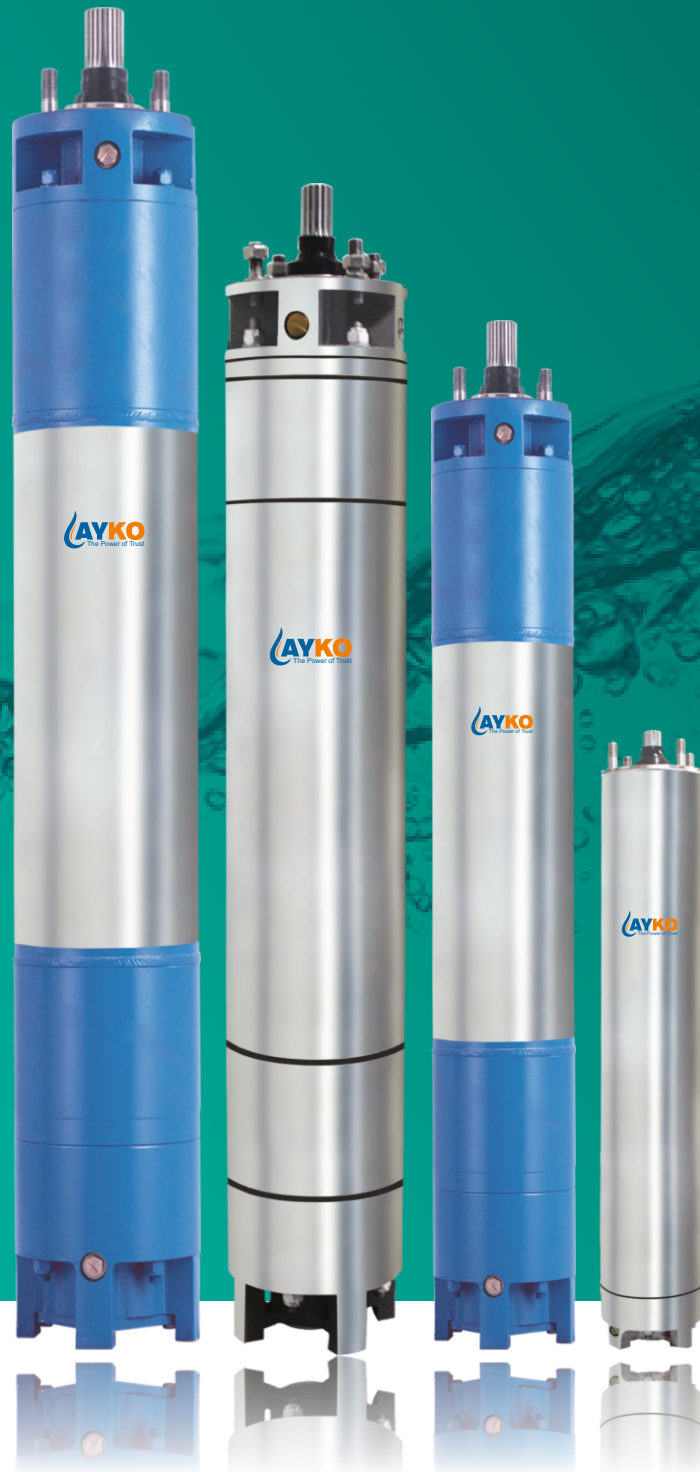

AYKO FLOWMATICK
DOOR NO-143C, NGRSTREET, KALAPATTY,
COIMBATORE - 641068
GSTIN/UIN : 33ABUFA1928J1Z7
Phone : 96554 51929
E-mail : aykocbe@gmail.com
Website : www.aykopumps.com